

# MP SEAL KIT

## CY2.1 CLICK/FIX

Part.no: 0090303



 **MasterFlow**®

LEADER IN HOT RUNNER TECHNOLOGY

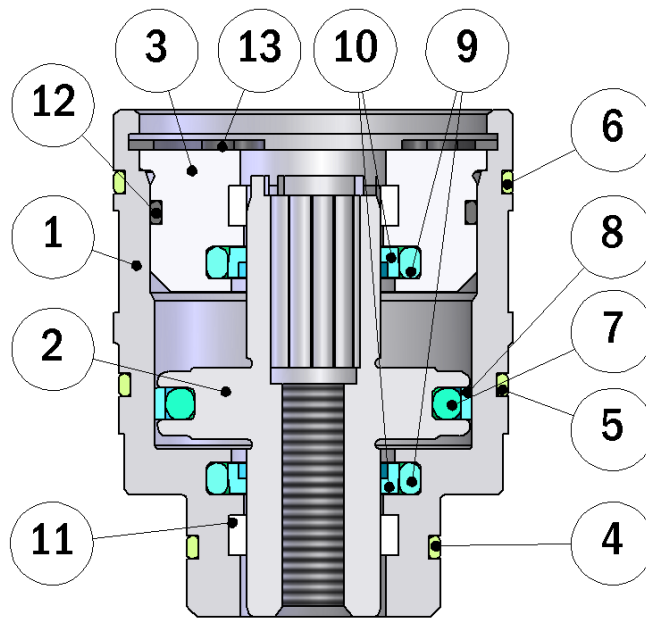

**INCLUDED IN DELIVERY**

13	-	CIRCLIP
12	1	MP ORING MFCY20 LID VITON
11	2	PISTON GUIDE BAND
10	2	MP PISTON SEAL ROD
9	2	MP PISTON SEAL ROD O-RING VITON
8	1	MP PISTON SEAL
7	1	MP PISTON SEAL O-RING VITON
6	1	MP ORING MFCY20 LARGE VITON
5	1	MP ORING MFCY20 MEDIUM VITON
4	1	MP ORING MFCY20 SMALL VITON
3	-	MP CYLINDER MFCY2.1 LID
2	-	MP PISTON CYLINDER MFCY/MFCB2.1 CLICK
1	-	MP CYLINDER MFCY2.1 HOUSE
Item	QTY.	Description

- Remove the circlip from cylinder.
- Remove the cylinder lid. Use a M4 screw and lift the lid.
- Remove the piston.
- Use a pointed tool to carefully remove all the old seals.
- Clean the CY2. Be extra careful to clean all the O-ring seats.
- Replace all seals in their respective place. Recommended to use MasterFlows seal replace tool (for number 10).
- After all seals are in place, start to re assemble the CY2.1.
- Place piston in the cylinder house. Press firmly until you feel that the piston is in the right place.
- Align the lid vertically and press firmly.
- Secure the lid with the circlip.